



F E D E R I C A  
**BUGATTI**

# INSTRUCTION MANUAL

Heating systems • Federica Bugatti

series **VARME**

**50 COND B**

**65 COND B**

Safe. Reliable. Warm.



FEDERICA BUGATTI LLC.  
MANUFACTURER: VARMECOM INC., MADE IN TURKEY

[FEDERICABUGATTI.COM](http://FEDERICABUGATTI.COM)



## Congratulations On Your Successful Choice!

You have purchased a high-efficiency boiler with an electronic ignition, a deep modulation, an electronic power control and a sealed combustion chamber.

Compared to traditional boilers, this condensing boiler allows energy to be recovered by condensing the water vapour, which is contained in the flue gases, thus for the same amount of heat produced, the appliance consumes less gas, and, in addition, flue gases of the condensing boiler contain fewer substances, making it more environmentally friendly. The materials which the boiler is made from and its regulation systems ensure safety, a high level of comfort and energy saving, allowing you to appreciate all the benefits of autonomous heating.

## USER GUIDE



**DANGER:** The instructions marked with this symbol must be strictly observed to avoid physical injury (wounds, bruises, etc.).



**DANGER:** The instructions marked with this symbol must be strictly observed to avoid accidents due to electric shock.



**DANGER:** The instructions marked with this symbol must be strictly observed to avoid the risk of fire or explosion.



**DANGER:** The instructions marked with this symbol must be strictly observed to avoid thermal injuries (burns).



**DANGER:** Instructions marked with this symbol must be strictly observed to avoid any malfunction and/or damage to equipment or other items.



**ATTENTION:** The instructions marked with this symbol are important information that must be read carefully.



## IMPORTANT APPOINTMENTS



**Read this manual carefully to use the boiler rationally and safely.** Keep the manual carefully as it may be needed again in the future. If the boiler is handed over to another user, the present manual must be delivered with the appliance.



**The commissioning** must be carried out by Federica Bugatti's authorized service centres or by a fully qualified technician to service and repair gas appliances, certified by Federica Bugatti Ltd; the warranty period starts from the date of the first start-up.



The manufacturer is not responsible for any misinterpretation of this manual due to incorrect translation, failure to follow the instructions contained in this manual, or for the consequences of any action not specified in this manual.



**Storage conditions and shelf life of the product:**

The product should be stored in the manufacturer's packaging, indoors with natural air circulation, under the standard conditions (no shock and vibration, temperature difference between -10 °C and +37 °C, air humidity up to 80%, non-hazardous and dust-free environments). If the circumstances are fulfilled, the shelf life of the appliance is up to 2 years. Subject to the rules of transportation, storage, installation and operation, the product has a service life of 10 years.



**Disposal of the product**

Disposal of the equipment must be carried out by authorized organizations for handling and recycling of household appliances in accordance with applicable regulations. To clarify the procedure for disposing of your old equipment, please contact your local public utility service or district administration office.

**DURING INSTALLATION**

**Installation** must be carried out by a qualified technician, who is obliged to comply with applicable national and local laws and regulations.

The boiler allows the heating medium to be heated to a temperature below boiling point. The boiler must be connected to a heating and/or hot water system compatible with its performance and capacity.

The boiler must be supplied with methane gas (G20). The condensate drain must be connected to the room sanitation, which is designed for condensate drainage and be verified (standard UNI 11071/08).

The boiler is intended to be used for the purposes strictly prescribed and, in addition, it is necessary to:

- Use only water as a heating medium;
- Protect the boiler from atmospheric influences;
- Keep the children and/or persons, who are unfamiliar with the usage, away from the boiler;
- Avoid misuse;
- Do not perform any actions to the sealed parts of the boiler;
- Avoid contact with the hot parts of the boiler during its operation.

**DURING OPERATION**

**Due to the danger, it is strictly forbidden to cover, even partially, the air intake of the exhaust ventilation in the room where the boiler is installed (UNI 11071/08).**



**Repairs must** only be carried out by Federica Bugatti authorized service centres using original spare parts (see warranty certificate); in case of malfunction, turn off the boiler (see instructions).



**If an odour of gas is present:**

- do not use electrical switches, telephones, or other objects that could cause sparks.
- open doors and windows immediately, allowing the air to ventilate the room.
- switch off the gas main.
- call a qualified technician.



**Before switching on the boiler, it is recommended to call a qualified technician to check the gas supply system according to the following points:**

- Tightness;
- Ensuring the inflow of the gas volume, which is required to feed the boiler;
- Availability of all the necessary safety and control devices stipulated by applicable standards;
- Whether the pressure relief valve is connected to the drainage funnel. The manufacturer is not liable for any damage caused by the water leakage as a result of the incorrect connection of the pressure relief valve to the drain system.
- The connection of the drain siphon with a drain funnel complying with the standards "UNI 11071/08" must be made in such a way that the condensate does not freeze and is properly drained off.



**Do not touch** the boiler with wet parts of your body.



**When maintaining or repairing objects** in the vicinity of chimneys and/or flue gas bleeding devices or fittings, the boiler must be switched off, after the work has been completed, have an authorized specialist check the boiler for the correct operation.

**The manufacturer reserves the right to make changes to the related manual at any time and without prior notice in order to continuously improve the product. Herein the document is for informational purposes and cannot be considered as a contract in relation to third parties.**

**TABLE OF CONTENTS**

<b>Scope of delivery</b> .....	4	7.3 Adjustment of the parameters (technical menu) .....	24
<b>Description of the boiler</b> .....	5	7.4 Information menu .....	25
1.1 General appearance .....	5	<b>Maintenance</b>	
1.2 Safety valves .....	5	8.1 Warnings.....	26
1.3 Control panel .....	5	8.2 General safety precautions during the maintenance .....	26
1.4 General features of the LCD .....	5	8.3 Remarks on Scheduled Maintenance .....	27
Description of the indicators, which display the status of the boiler .....	6	<b>Warranty Conditions</b> .....	27
Error codes appearing on the display .....	6	<b>Warranty Card</b> .....	28
<b>Instructions for use</b>			
2.1 Warnings.....	8		
2.2 Commissioning the boiler .....	8		
2.3 Operating modes .....	8		
2.4 DHW temperature adjustment .....	8		
2.5 "Anti Legionella" System .....	8		
2.6 Heating circuit temperature adjustment.....	9		
2.7 Heating function for the heating circuit, which an outdoor sensor is connected .....	9		
2.8 Switching off the boiler .....	10		
<b>Useful Recommendations</b>			
3.1 Pre-operations to be performed before commissioning the boiler .....	10		
3.2 Filling and adjusting the pressure in the heating system .....	10		
3.3 Features of the heating circuit .....	11		
3.4 Precautional functions .....	11		
3.5 The prolonged inactive state of the boiler and "Anti-freeze" function .....	11		
3.6 Possible malfunctions, which may occur in boiler operation .....	12		
<b>Technical Features</b>			
4.1 Overall view .....	13		
4.2 Circuit diagram .....	14		
4.3 Electrical diagram .....	15		
4.4 Hydraulic curve .....	16		
4.5 FEDERICA BUGATTI 25, 35, 42 COND B Technical Features.....	17		
<b>Installation</b>			
5.1 Warnings .....	18		
5.2 Safety precautions for installation .....	18		
5.3 Installation of the boiler .....	19		
5.4 Connection of buffer tank sensor and external 3-way motorized valve .....	19		
5.5 Dimension and lengths of the chimneys .....	20		
5.6 Wall-mounted chimney kit .....	21		
5.7 Placement of the exhaust diverters .....	21		
<b>Gas Adjustments</b>			
6.1 Preliminary operations before the first commissioning .....	22		
6.2 Access to the internal parts of the boiler.....	22		
6.3 Filling the siphon of condensate drainage ...	23		
6.4 Commissioning the boiler .....	23		
6.5 Control and adjustment of CO <sub>2</sub> concentration	23		
<b>Parameter Adjustments (Technical Menu)</b>			
7.1 Accessing the parameters .....	24		
7.2 Making adjustments .....	24		

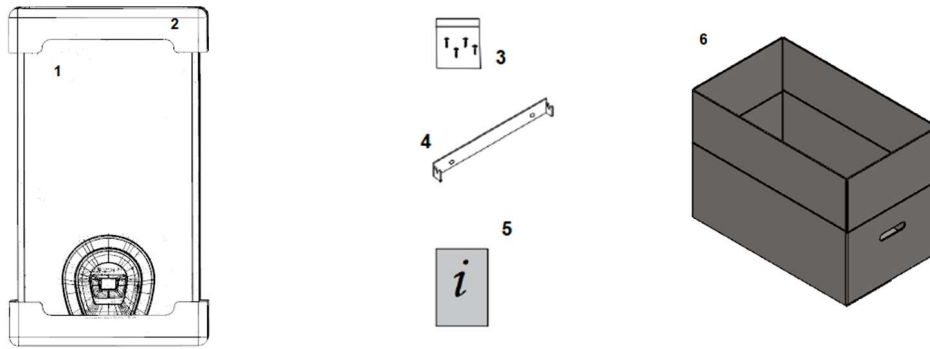
**Scope of Delivery**

- 1- gas boiler
- 2- styrofoam
- 3- fixing material (screws with accessories)
- 4- hinge bar
- 5- instruction manual set, condensate drain siphon, flexible hose
- 6- box

**Introduction**

**The instruction manual is an integral and supplementary part of the product and is supplied with the boiler.**



Read the instructions manual carefully for all important information for the safe installation, operation and maintenance of the appliance.

- The dangers of carbon monoxide (CO): CO is an odourless and colourless gas. When installing a boiler with room air intake (type B2), constant ventilation of the room is extremely important. Ventilation must be carried out in accordance with the applicable standards and regulations. Covering or neutralizing ventilation can lead to serious health consequences such as carbon monoxide poisoning, irreversible organ damage and even death. In addition, a mixture of CO and O<sub>2</sub> can be explosive.
- A qualified technician is a person who has specialized technical training and experience in the installation of domestic heating appliances and acts in accordance with the norms and regulations.
- The user may only perform the operations listed in the "User Manual" section.
- The manufacturer accepts no responsibility for any damage caused by incorrect installation, improper use, and non-compliance with the applicable regulations and instructions.
- **ATTENTION!** A gas boiler is used for heating the water to a temperature below boiling point at atmospheric pressure and must be connected to a heating and/or hot water supply system according to its characteristics and capacity.
- Packaging objects (cardboard, nails, plastic bags, etc.) should not be left within reach of children, as it may be dangerous.
- Before any cleaning or maintenance of the boiler, disconnect it from the mains and switch off the gas main.
- In the event of a malfunction and/or improper appliance operation, disconnect it immediately and do not attempt to repair it by yourself.
- The boiler must be maintained and repaired only by a qualified technician using the original spare parts. This requirement must be strictly observed.
- If the appliance needs to be dismantled, remove any remaining dangerous objects and eliminate them by the regulations in force.
- When relocating the appliance (e.g. moving), make sure that the operating instructions are maintained and handed over to the future owner and/or installer.
- The appliance should only be used for strictly recommended purposes. Any other use is considered dangerous and improper.
- It is strictly forbidden to use the equipment for other than its intended purpose.
- The appliance must be mounted exclusively on the wall.
- This instruction manual is an important part of the product and is supplied with it.
- Read the instructions carefully, applying all information for the safe installation, usage, and maintenance of the appliance.
- Installation must be carried out by a qualified technician in accordance with the applicable regulations and manufacturer's instructions.

## 1. DESCRIPTION OF THE BOILER

### 1.1 General Appearance

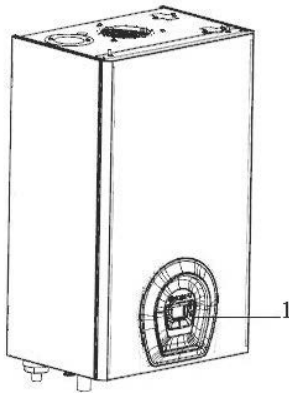

Figure 1.1  
Control Panel (1)

### 1.3 Control Panel

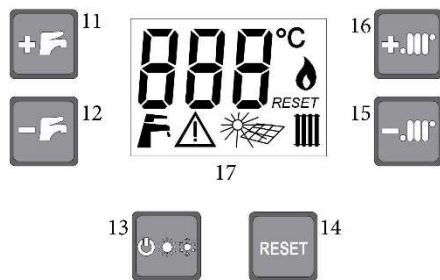

Figure 1.3

- 11 Increasing DHW temperature
- 12 Decreasing DHW temperature
- 13 Mode selection:  
ON / OFF / "SUMMER" / "WINTER"
- 14 Error reset button
- 15 Decreasing the heating circuit temperature
- 16 Increasing the heating circuit temperature
- 17 LCD

### 1.2 Safety valves

- (i)** Safety valves must be installed on the gas inlet.
- (i)** It is necessary to install safety valves on the inlet and outlet of the boiler's threaded connections. A dirt filter must be plugged into the return line of the heating system in order to avoid foreign particles entering the boiler, which can cause malfunction of the boiler.
- (i)** The drawings in this manual illustrate only one of several possible mounting solutions for installing valves, pipes, and connections.

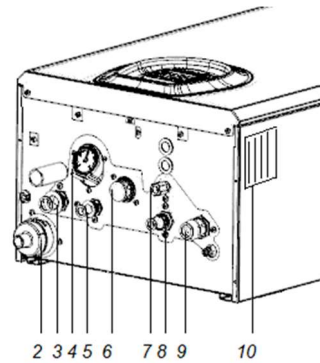

Figure 1.2

- 2 Condensate drain siphon
- 3 Heating outlet (3/4")
- 4 Pressure gauge
- 5 DHW outlet (1/2")
- 6 Gas connection (3/4")
- 7 Replenishing valve
- 8 DCW inlet (1/2")
- 9 Heating return line (3/4")
- 10 Sticker of the features and date of manufacture

## DESCRIPTION OF THE DISPLAYS

### 1.4 General features of the LCD

For the technical features of the boiler, see the section "TECHNICAL FEATURES" on page 16.



















Figure 1.4



- GC Boiler communication with the device via OPEN THERM protocol
- CSF Indication of boiler operation in test mode
- HI Indication of boiler operation at maximum output
- LO Indication of boiler operation at minimum output





### INDICATIONS

- 000°C Temperature and possible malfunctions
- 0000 Turn off
- F DHW operation
- III Heating operation

- Flame presence
- Boiler failure
- Not in use
- Error reset

Description of the indicators, which display the status of the boiler										
Boiler status	Indication on the display									
	Numbers, letters		Indications					Display backlight		
Switched off	OFF		-					-		
"SUMMER" mode hot water demand expectation	55°	The present hot water temperature is displayed.		Turns on.		-				
"SUMMER" mode hot water preparation.	35-60°	The present heated water temperature is displayed.		Turns on.		Turns on.		-		
"SUMMER" mode hot water preparation temperature adjustment.	35-60°	The adjusted domestic hot water temperature is displayed.		Blinks.					Goes off 60 seconds after operations are performed.	
"SUMMER" mode heating circuit temperature adjustment	-		-					-		
"WINTER" mode standby.	35-80°	The present heating temperature is displayed.		Turns on.		Blinks, on demand.		-		
"WINTER" mode hot water preparation demand.	35-60°	The present heated water temperature is displayed.		Blinks.		Turns on.		Turns on.	-	
"WINTER" mode heating demand.	35-80°	The present heating circuit temperature is displayed.		Turns on.		Blinks.		Turns on.	-	
"WINTER" mode hot water preparation temperature adjustment.	35-60°	The adjusted domestic hot water temperature is displayed.		Blinks.			Turns on demand	Goes off 60 seconds after operations are performed.		
"WINTER" mode heating circuit temperature adjustment.	35-80°	The adjusted heating circuit temperature is displayed.		Blinks.			Turns on demand	Goes off 60 seconds after operations are performed.		

Error codes appearing on the display			
Error code	Description	Type of error	Actions to take
E 01	When gas does not flow into the boiler, or ignition fails for any reason, the motherboard will display such an error. An error code may occur in both cases. Contact an authorized Federica Bugatti Service Center.	Ignition failure.	Press the reset button 
E 02	If the heating outlet temperature is above 100°C, the safety thermostat shuts the boiler for safety purposes and the error code appears on the LCD. If this malfunction occurs frequently, contact Federica Bugatti Authorized Service Center.	Safety thermostat has been triggered (the water temperature in the heating system outlet exceeds the permissible limit).	Press the reset button 
E 03	If the flue gas sensor circuit is interrupted for 3 seconds, lockdown occurs. The circuit of the flue gas sensor should be closed. If this malfunction occurs frequently contact the Federica Bugatti Authorized Service Center.	The air pressure switch has been triggered.	Press the reset button 
E 04	The error code occurs when the water pressure in the heating system drops below 0.5 bar. The water pressure drops if leakage is present in the heating system. The system should therefore be inspected for leaks. Fill the water by switching on the replenishing valve until the pressure gauge indicates the water pressure at 1.5 bar.	Low water pressure in the heating system.	Once the malfunction is eliminated, the boiler re-operates automatically

<b>E 05</b>	Occurs when the NTC temperature sensor in the heating system malfunctioned. Contact the Federica Bugatti Authorized Service Center.	The NTC surface temperature sensor in the heating system malfunctioned.	Once the malfunction is eliminated, the boiler re-operates automatically
<b>E 06</b>	The error code occurs if the DHW temperature sensor malfunctioned. Contact the Federica Bugatti Authorized Service Center.	DHW temperature sensor malfunctioned.	Warning, the boiler continues to work.
<b>E 15</b>	Occurs when the temperature sensor in the heating system malfunctioned. Contact the Federica Bugatti Authorized Service Center.	NTC temperature sensor in the return line of the heating system malfunctioned.	Once the malfunction is eliminated, the boiler re-operates automatically
<b>E 25</b>	When the NTC temperature sensor of the heating system measures the temperature below 1°C for 10 seconds, the motherboard displays such an error, thus the main heat exchanger is detected as "frozen". The burner stops operating. The pump is not activated. When the temperature rises to + 3°C, regular operation starts automatically. - Drain the water from the boiler - Cut the power off - Switch off the gas valve - Wait until the temperature in the main heat exchanger reaches +3 °C. Then refill the boiler with water again and try to start it up. - If the error appears again, contact the Federica Bugatti Authorized Service Center.	Freezing.	Once the malfunction is eliminated, the boiler re-operates automatically
<b>E 41</b>	If a spurious flame is detected for at least 10 seconds even if the burner is not switched on. If the flame indicator goes off for at least 1 second, regular operation continues. Contact the Federica Bugatti Authorized Service Center.	"Spurious" (parasite) flame	Once the malfunction is eliminated, the boiler re-operates automatically
<b>E 42</b>	If the flame detection signal stays out of range for 15 seconds, error occurs. When the flame detection signal is in the range, for at least 2 seconds, the boiler continues to operate. Contact the Federica Bugatti Authorized Service Center.	Ionization electrode has been malfunctioned.	Once the malfunction is eliminated, the boiler re-operates automatically
<b>E 44</b>	Error occurs if there is a problem going on with the flue gas temperature sensor (open/ short circuit). During relevant failure, DHW and heating demands are stopped. If the malfunction reoccurs, contact the Federica Bugatti Authorized Service Center.	Flue gas temperature sensor malfunctioned.	Once the malfunction is eliminated, the boiler re-operates automatically
<b>E 26</b>	If the temperature of the heating system NTC sensor is above 95°C, error occurs. After the temperature drops to 85°C, the boiler starts re-operating automatically.	The temperature exceeds 95°C.	Once the malfunction is eliminated, the boiler re-operates automatically
<b>E 16</b>	If the signal from the fan has not been received for 5 seconds even though the fan is switched on, lockout occurs. If the error reoccurs, contact the Federica Bugatti Authorized Service Center.	The feedback signal from the fan can not be received.	Press the reset button 
<b>E 40</b>	If the measured RPM differs from the target RPM within 60 seconds, lockout occurs.	Fan signal out of acceptable range.	Press the reset button 
<b>E 46</b>	In the event of an error related to the gas valve actuator and feedback check circuitry, lockout occurs.	Gas valve feedback error.	Press the reset button 
<b>E 45</b>	If the temperature of the flue gas NTC sensor exceeds 95°C for 3 seconds, lockout occurs.	Flue gas temperature exceeds 95°C.	Press the reset button 

**INSTRUCTIONS FOR USE****2. INSTRUCTIONS FOR USE****2.1 Warnings**

Even if the boiler is only used for domestic hot water, make sure that the heating system is properly filled with heating medium. Otherwise, it must be filled appropriately according to the section "Filling and adjusting the pressure in the heating system" on page 13. All boilers are equipped with a frost protection system, which is activated when the boiler temperature drops below 5 °C, therefore **the boiler must not be switched off**. If the boiler is not used in cold seasons and it has a chance to be frozen, appropriate instructions must be fulfilled according to the section "Anti-freeze function" on page 13.

**2.2 Commissioning the boiler**

• Boiler valves have to be switched on, see. Figure 2.1.

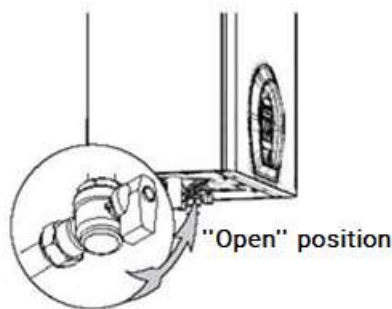

Figure 2.1

• Using a double pole switch, which is provided during the installation, switch on the power supply. On LCD the following symbols will appear in order. see Figure 2.2.

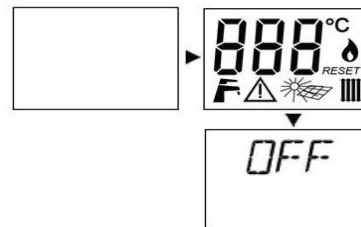













Figure 2.2

**2.3 Operation modes**

Choices can be made between Winter mode (hot water + heating), Summer mode (only hot water) or only heating mode by using the button. To the button:

- Press once to operate the boiler in summer mode (only hot water). On display, only  symbol will be shown.
- Press once to operate the boiler in winter mode (hot water + heating). On display   symbols will be shown.
- Every additional touch to  button, will change the boiler mode cyclically:  - "Off" mode,  "Summer",  "Winter" and  only "Heating". In winter mode  on demand of the room thermostat, (if it exists) burner switches on and the warmed-up heating medium begins to circulate in the heating system. In the event of a demand for hot water and heating simultaneously, the DHW request has priority over the heating mode. Since DHW requests are short in duration, usually, this situation does not affect the quality of the heating system.

**2.4 DHW temperature adjustment**

- The hot water temperature can be adjusted by pressing the  and  buttons (the temperature value during the adjustment is shown on the display under the  symbol). The adjusted temperature value is displayed for an additional 5 seconds after the last press afterwards, the display returns to regular mode.



**2.5 "Anti Legionella" System**

The "Anti-Legionella" system eradicates active microorganisms in the water and prevents their reproduction in the future. In order to overcome this problem permanently, periodical treatment of the buffer tank will be enough, since the function is active by default. Adjustment and deactivation of the function must be performed by a technician, who represents the Federica Bugatti Service Center during the commissioning. Federica Bugatti single-circuit gas boilers, connected to an indirect boiler by means of an NTC sensor, which uses the "Antilegionella" thermal treatment function. The "Antilegionella" system is automatically activated once a week by heating the water in the buffer tank to 70°C and maintaining it for one hour.



## 2.6 Heating circuit temperature adjustment

**Notification:** If a low-temperature kit or outdoor temperature sensor is installed for the heating system, please read the instructions for the equipment.

**Notification:**  Please do not confuse the heating circuit temperature described here with the room air temperature set on the room thermostat.



• **Heating temperature adjustment:** The heating circuit temperature is adjusted by using  and  buttons.

(adjusting the temperature, value is shown on screen below  symbol). In the meantime, the radiator icon blinks and the adjusted value is shown on the screen. After pressing the button last time, adjusted temperature is shown for 5 seconds, afterwards, the screen returns to its ordinary appearance. Usually, due to the fact that onset of the cold weather and/or the building lack of enough isolation (or if you notice that the room temperature does not reach the adjusted temperature in the room thermostat even though the burner has been switched on for a long time), please increase the temperature value in the heating system. In a reverse situation, due to thermal inaction, if you notice that the room temperature exceeds the adjusted value in the thermostat significantly, it is recommended to reduce the temperature.

**If an outdoor temperature sensor is installed additionally, the temperature in the heating circuit changes automatically, also the purpose of the buttons  and  will be different from above.** In these circumstances see the section "Heating function for the heating circuit, which outdoor sensor is connected".

## 2.7 Heating function for the heating circuit, in which an outdoor sensor is connected

The boiler automation provides the operation in the weather-dependent mode and has the possibility of connecting an external temperature sensor. It allows the boiler to be operated with greater comfort for the user, as well as to influence the fuel economy during the operation of the equipment. If it has an outside air sensor and the temperature measured by it, is below + 50°C, the boiler automatically switches to operate according to the outside air sensor. In this mode,

the dissipation coefficient is controlled by the parameter "P20" and the buttons  and  buttons adjust the set room temperature between 15°C and 25°C. The reference set of the heating circuit temperature is determined by the heat dissipation coefficient and the room temperature setpoint value. The boilers operate according to this defined set reference heat value for the heating.



**Note:** The calculated set temperature of the heating circuit for the value in the operation mode with weather-dependent automation never exceeds the maximum temperature range and never falls below the minimum temperature range of the central heating mode.

The formula for calculating the slope factor:

$$T_i = [(T_{Room} - T_e) * (K_e / 10)] + T_{Room}$$

T<sub>i</sub>: reference heating set calculated by the system;

T<sub>Room</sub>: pre-set room temperature;

[15°C ÷ 25°C] Adjusted values by using  and  buttons.

T<sub>e</sub>: outdoor temperature;

K<sub>e</sub>: "P20" [5 ÷ 35] the adjusted value of the heat dissipation coefficient according to the parameter.

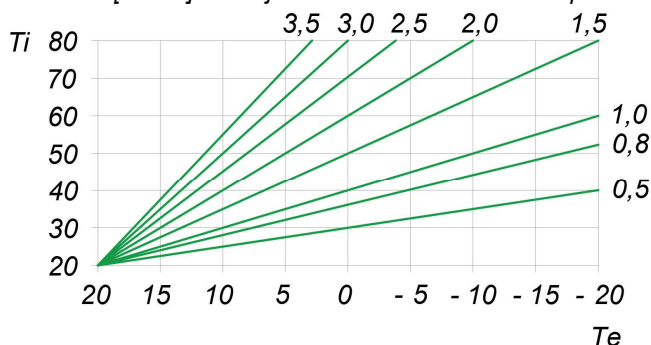

T<sub>Room</sub> = temperature curve values at 20°C

## 2.8 Switching off the boiler

Press the  button until **OFF** appears on the display.

Actions to take if you are planning not to use the boiler for a long period of time:

- Switch off the power;
- Shut off the boiler valves;
- If it is necessary, drain the hydraulic circuits, see “Evacuating the system” on page 14.

## USEFUL RECOMMENDATIONS

### 3. USEFUL RECOMMENDATIONS

#### 3.1 Pre-operations to be performed before commissioning the boiler

1- Heating circuit pressure gauge

2 – Gas connection

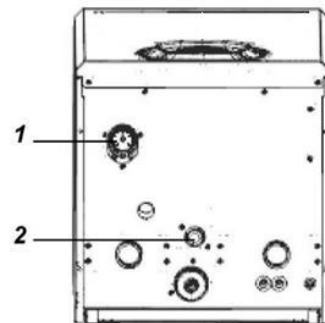

Figure 3.1

- Make sure that the boiler is connected to the gas main (2).
- Make sure that the boiler is energized and on the display only **OFF** symbol appears.
- With the help of the pressure gauge (1) make sure that the cold system pressure is between 0,7 and 1,5 bar (the most appropriate operation value is between: 1÷1,5 bar). The boiler stops working below 0,5 bar pressure. In that circumstance, with the help of the replenishing valve (2) fill up the system until the pressure gauge shows at least 1,5 bar.

#### 3.2 Filling and adjusting the pressure in the heating system

Completing all of the hydraulic connections of the system, to filling operation can proceed. The operation must be done by following the instructions below:

- Check whether the automatic air bleeding valve, which is integrated into the circulating pump is unscrewed. If it is not, rotate and leave it open.
- After completing the operation, if it is necessary to fill the system to neutralize the pressure in the system, please seal the connection or valve, which are used to fill in the heating system.
- Gradually switch on the replenishing valve (2).

- Check whether the installed automatic air bleeding valves are operating;
- Check whether the pressure indication arrow on the pressure gauge (1) shows **1,0 bar (maximum 1,5 bar)** pressure;
- Please switch off the replenishing valve (2) and switch on all of the air bleeding valves of the radiators in the heating system;
- Repeat the process to bleed and pressurize the heating system until all of the air has been removed;
- If the heating system is filled up and air in it is vented, the process could be considered done. After some time, it may be necessary to remove the remaining air again because it may still exist in the system.

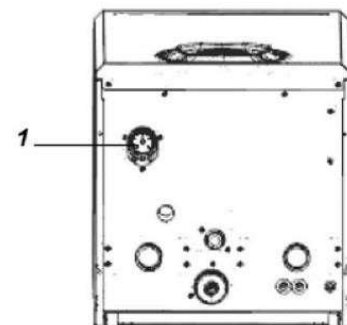

Figure 3.2

### 3.3 Features of the heating circuit



**Ensure that the DHW and heating system pipes are not used as earthing connections.**

Efficiency, durability and safety of the boiler straightforwardly depends on the quality and filtration of the used water. Proper water purification improves the protection of systems against corrosion (and therefore against lockout, noise, leaks, etc.) and against scale, which largely reduces the efficiency of heat exchanger (it is estimated that 1 mm of limescale reduces the efficiency of the heating medium by 18%, where it has formed). In the heating system, it is recommended to use water as a heating medium. The quality of the water, should comply with the parameters given below:



- pH value should be in the range of 7-8,5 pH;
- Overall flow should not be exceed the 3.5 mval/l;
- Iron content should not be more than 0.3 mg/l.

Flush the heating system thoroughly with water before connecting it to the boiler. The process will help to reduce (or eliminate) residual debris such as welding drips, mastic, dirt deposits of various origins, wax, rust and other accumulations from the heating system and radiators. Otherwise, these particles can damage internal components of the boiler, e.g. the circulation pump.

- **In the event of a rusty or polluted system** special cleaning products should be used for flushing in the quantities and proportions recommended by the manufacturer of such product.
- If the water at the boiler inlet has a hardness higher than 3.5 mg-eq/l, a water softener must be installed to reduce the water hardness.

- The drain from the heating system pressure relief valve (3 bar) must be connected to the sewage system. Failure to do so will result in flooding of the room in the event of the pressure relief valve activation, for which the boiler manufacturer will not be held liable.
- The boiler is designed for closed heating systems with forced circulation.
- To provide long and efficient operation of the boiler and heating system, it is recommended to install the heating system from polymer or copper pipe.
- A mechanical filter must be installed on the return line of the heating system.
- It is preferable to use modern low-inertia radiators (steel panel radiators, aluminium radiators, etc.) as heating devices.

### 3.4 Precautional functions

**Three-way valve lockout prevention function**

After 24 hours of inactivity, the 3-way valve changes its position for 10 seconds to prevent blockage. If a demand occurs during the anti-lock operation time, the anti-lock is terminated. The function is also active in lockout or standby state.

**Pump jam protection function**

After 24 hours of inactivity, the pump is switched on for 25 seconds to prevent clogging. If the request occurs during the anti-clogging time, the function timer starts counting again. The function is also active in lockout or standby state.

**Anti-freeze function**

If the water temperature measured by the heating circuit temperature sensor is beneath the bottom threshold of the frost prevention function for the heating or DHW circuit, the burner switches on. Once the flame is detected, the modulation level is set to the minimum. The frost protection function is active in "Summer" or "Off" mode. In "Winter" mode, when there is no heat demand on the room thermostat, it activates. Only the pump is energized in the lockout state.

**Automatic boiler stop function**

The boiler stops operating for 15 seconds if it is switched on continuously for 24 hours. The boiler returns to the required operating mode after 15 seconds.

### 3.5 The prolonged inactive state of the boiler and "Anti-freeze" function

Leaving the combi boiler in **OFF** mode during its inactivity provides freeze protection by the functions integrated into the motherboard, which command the heating of the relevant components when the temperature drops below the value adjusted by the manufacturer as the anti-freeze threshold. The anti-freeze function is performed by switching on the burner and the pump. In case of a power failure and its subsequent recovery, the combi boiler will check the temperature utilizing sensors and in case of detection of freezing, thanks to a special automatic control process, the combi boiler will indicate the error - **E 25**. For further information, see the relevant error description in the section "Faults in combi boiler operation and how to eliminate them".

**Note:** The combi boiler is provided with a system that protects the main components against rare cases of lockout due to the combi boiler being idle (not used) in the presence of water and scale. The lockout protection system cannot operate in case of power failure. Furthermore, the combi boiler in standby mode periodically operates the

main components. It occurs even in the case the combi boiler is in an error state (the display shows **RESET**), but only if the system pressure is within the operating range.

- (i)** Before switching on the combi boiler, after a long period of non-use, have the pump checked by a technician to ensure that it is not blocked due to prolonged inactivity: unscrew the blind plug in the centre of the pump's body and, having gained access to the rotor, rotate it with a screwdriver or any other appropriate tool).

To activate such functions, follow the instructions below:

- the combi boiler must be plugged into the gas and electric mains and the gas valve must be switched on;
- the combi boiler must be switched to the mode **OFF**;
- the pressure in the heating circuit should be **in the optimum range of 1.0 bar to 1.5 bar** (unheated heating medium), **a minimum of 0.7 bar**.

If the gas supply is absent or for any other reason the combi boiler enters an error state (the display will show

**RESET**), the burner will not be able to ignite. In such a circumstance, the anti-freeze function will only be performed by activating the pump.

- (i)** **Attention!** The "Anti-freeze" function does not protect the sanitary and heating circuit outside the combi boiler. Hence, we recommend draining the DHW and HTW systems (pipes, standpipes) that may be at risk of freezing.

- (i)** In case of freezing danger at certain external points of the heating system, it is recommended to use a specific antifreeze, usually based on propylene glycol, following the instructions of its manufacturer. Pay attention to the correct concentration of antifreeze in the water, adding an incorrect amount of antifreeze to the water may deform the o-rings and cause noises or water leakage from the combi boiler or the system. The manufacturer accepts no responsibility for such damage.

If antifreeze is used in the heating system, it is necessary to mechanically limit the heat output of the combi boiler by 20 -25% of the nominal value, and additionally check the sufficiency of the combi boiler expansion tank capacity. Failure to fulfil these requirements may result in damage to the internal components of the combi boiler, which will not be accepted for warranty replacement.

**A qualified technician should inform the user about the type of antifreeze injected into the system and instruct on its purpose, properties and specifics of use. The manufacturer does not recommend filling the system with antifreeze. This may invalidate the warranty for the appliance. Consult the manufacturer for the application of antifreeze.**

### 3.6 Possible malfunctions, which may occur in boiler operation.



**Do not carry out by yourself any repair works that are the competence of a specialized technician, as well as actions not specified in the "User Manual" section. The accessories used for connection and operation of the boiler must be original. The manufacturer is not liable for improper, inappropriate and erroneous usage of the boiler, as well as non-original accessories and spare parts.**

**TECHNICAL FEATURES**

**4. TECHNICAL FEATURES**

**4.1 General appearance**

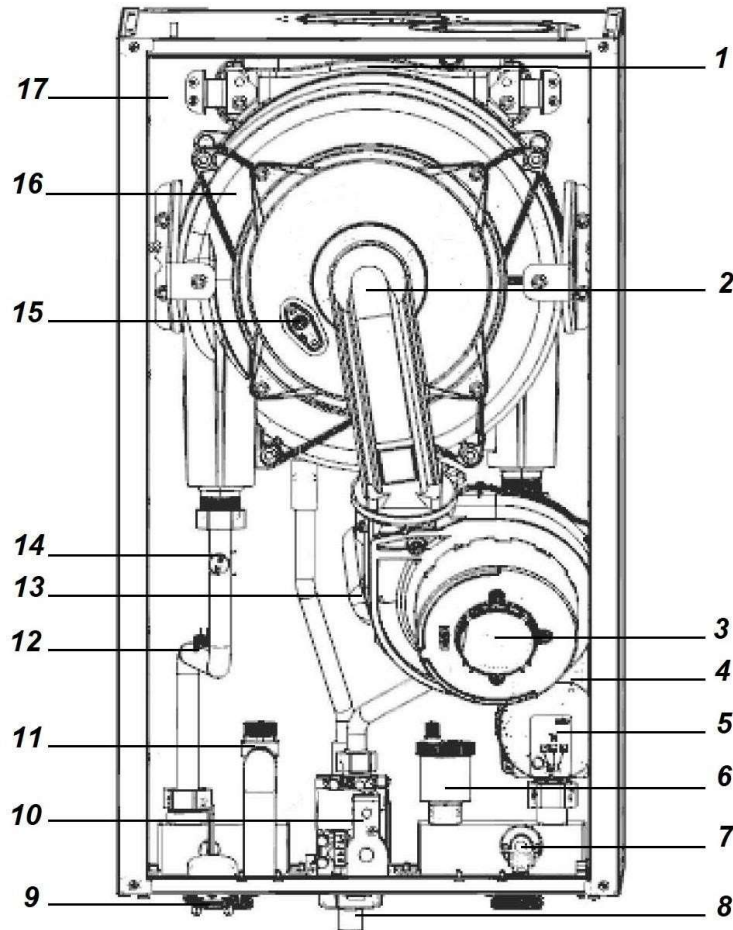

**Figure 4.1**

- |   |  |
|---|--|
| 1 Flue gas temperature sensor;                        | 10 Gas valve;  |
| 2 Heat exchanger manifold group;                      | 11 6 bar pressure relief valve;                        |
| 3 Fan;  | 12 Heating circuit outlet line NTC temperature sensor; |
| 4 Heating circuit return line NTC temperature sensor; | 13 Mixer;  |
| 5 Circulating pump;                                   | 14 Safety thermostat;                                  |
| 6 Automatic air bleeding valve;                       | 15 Ignition and ionization electrode;                  |
| 7 Low water pressure switch;                          | 16 Heat exchanger;                                     |
| 8 Condensate water drain siphon;                      | 17 U body;   |
| 9 Pressure gauge;                                     |  |

## 4.2 Circuit diagram

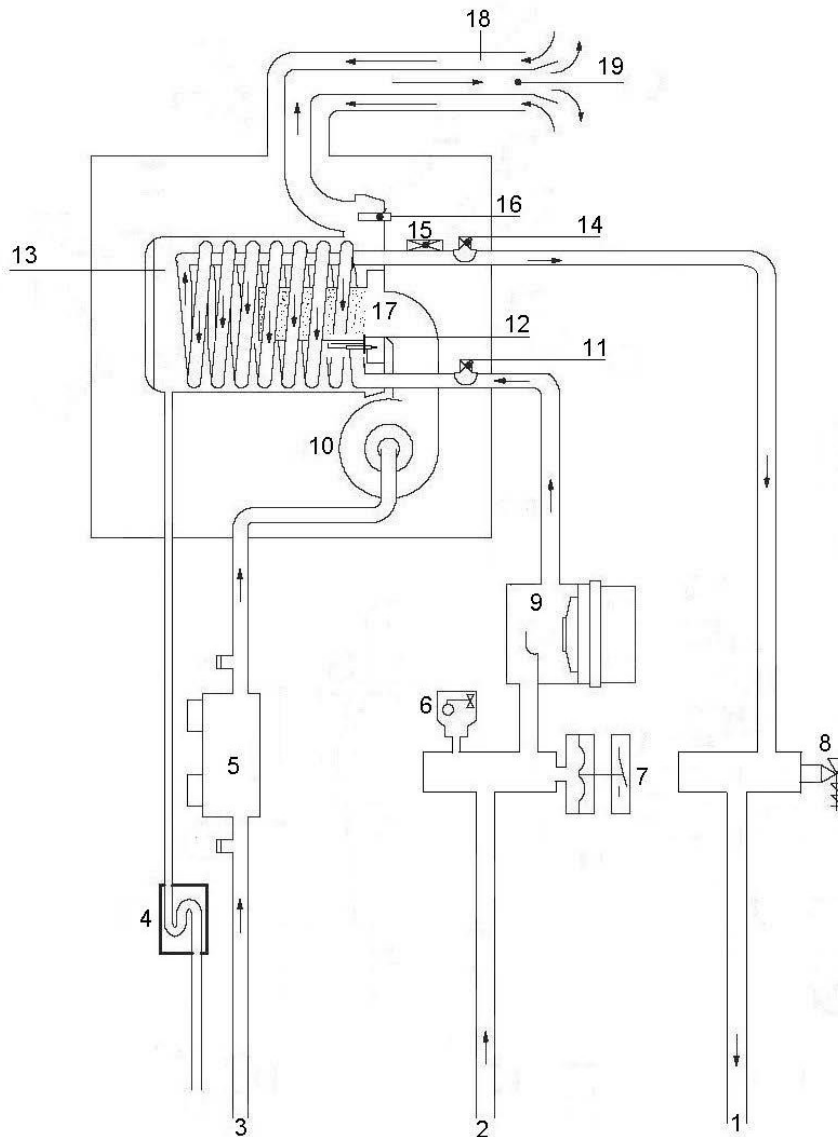

**Figure 4.2**

- |  |   |
|--|---|
| <p>1 Heating circuit outlet line;<br/>                 2 Heating circuit return line;<br/>                 3 Gas inlet;<br/>                 4 Condensate water drain siphon;<br/>                 5 Gas valve;<br/>                 6 Automatic air bleeding valve;<br/>                 7 Low water pressure switch;<br/>                 8 6 bar pressure relief valve;<br/>                 9 Circulating pump;<br/>                 10 Fan;<br/>                 11 Heating circuit return line NTC temperature sensor;</p> | <p>12 Ignition and ionization electrode;<br/>                 13 Heat exchanger;<br/>                 14 Heating circuit outlet line NTC temperature sensor;<br/>                 15 Safety thermostat;<br/>                 16 Flue gas temperature sensor;<br/>                 17 Burner;<br/>                 18 Clean air inlet;<br/>                 19 Flue gas ventilation;</p> |
|--|---|

### 4.3 Electrical diagram

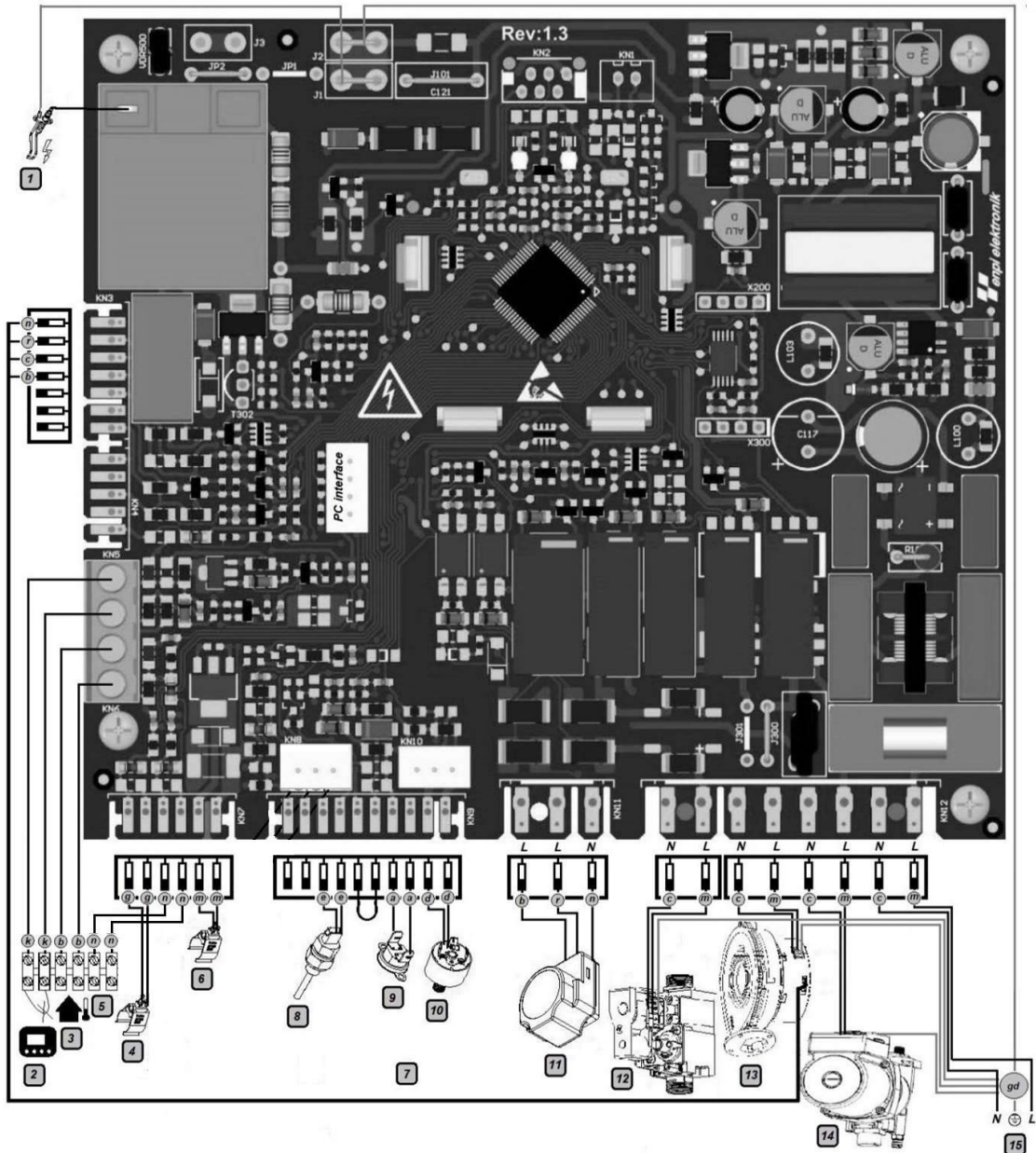

Figure 4.3

<b>gd</b>	Yellow / Green	<b>1</b>	Ignition and ionization electrode
<b>g</b>	Yellow	<b>2</b>	On/Off Room thermostat / Open Therm
<b>k</b>	Pink	<b>3</b>	Outdoor air temperature sensor
<b>m</b>	Brown	<b>4</b>	Heating circuit outlet line temperature sensor
<b>c</b>	Blue (Dark)	<b>5</b>	Buffer tank sensor connection terminal
<b>n</b>	Black	<b>6</b>	Heating circuit return line NTC temperature sensor
<b>b</b>	White	<b>8</b>	Flue gas temperature sensor
<b>d</b>	Green	<b>9</b>	Safety thermostat
<b>a</b>	Orange	<b>10</b>	Low water pressure switch
<b>e</b>	Grey	<b>11</b>	3-way motorized valve
		<b>12</b>	Gas valve
		<b>13</b>	Fan
		<b>14</b>	Circulating pump

### 4.4 Hydraulic curve

The hydraulic curve represents the dependence of the pressure allowed in the heating system on the flow rate

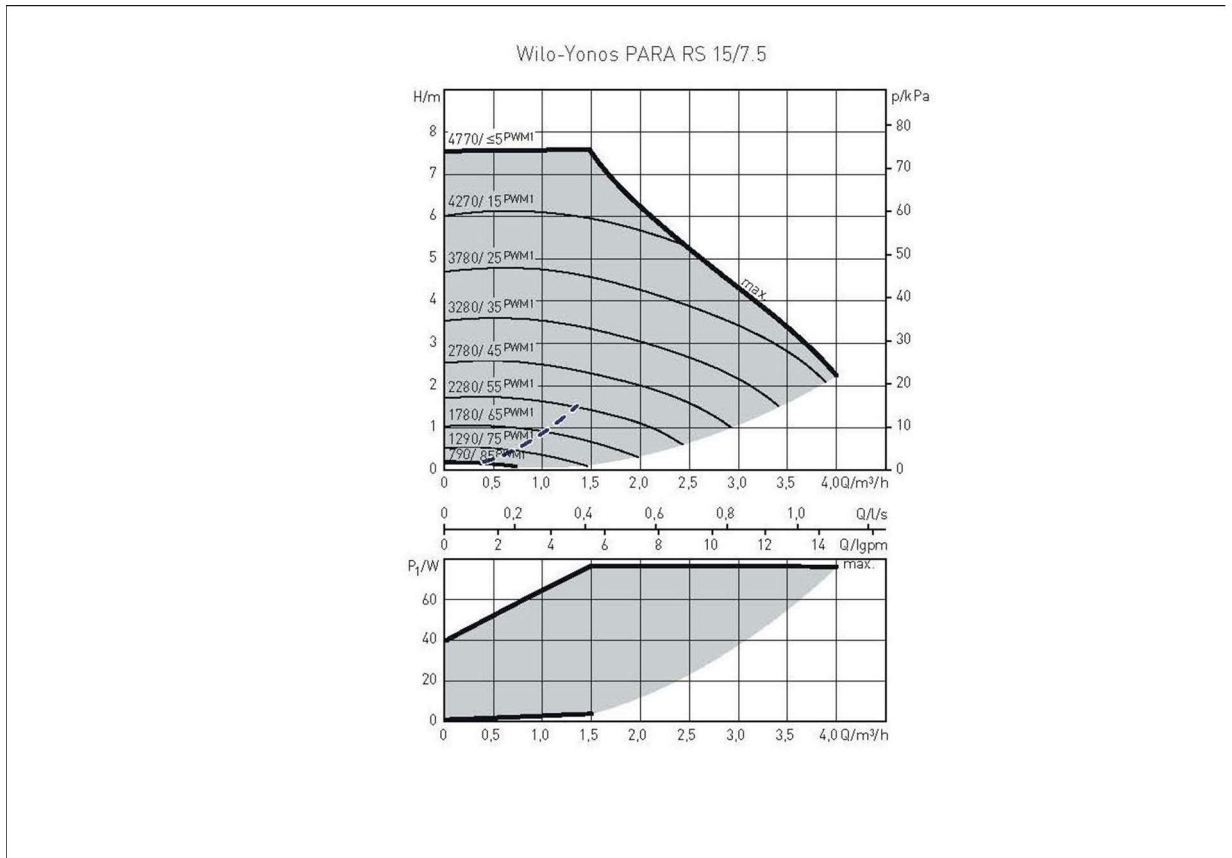

Figure 4.4

**4.5 FEDERICA BUGATTI VARME 50 COND, 65 COND Technical Features**

<b>Parameters</b>	<b>Unit of measurement</b>	<b>VARME 50 COND</b>	<b>VARME 65 COND</b>
Nominal heating output of the system, max	Kw	50.4	65.3
Nominal heating output of the system, min	Kw	12	12
Heating output, min/max	Kw	11.9 / 49.3	11.9 / 64.7
Efficiency (80/60°C)	%	102	102
NOx class	-	6	6
Flue gas temperature	°C	56	57
Energy efficiency class		A	A
<b>Heating circuit</b>			
Operating pressure, min	Bar	0.8	0.8
Operating pressure, max	Bar	6	6
Heating circuit temperature range	°C	35-80	35-80
<b>DHW Circuit</b>			
DHW temperature	°C	35-60	35-60
<b>Electrical Features</b>			
Voltage / Frequency	V/Hz	230/50	230/50
Power consumption	Watt	190	190
Protection class		X4D	X4D
<b>Gas pressure and flow</b>			
G20 natural gas (inlet pressure), min/max	Mbar	6/20	6/20
G20 Gaz flow rate	m³/s	0.9 - 5	0.9 - 6.2
<b>Overall Features</b>			
Weight	kg	48.5	48.5
Size	mm	708/412/488	708/412/488
Gross, weight	kg	52	52
Package size	mm	782/468/565	782/468/565
CO <sub>2</sub> min	%	8.5	8.5
CO <sub>2</sub> max	%	8.5	8.5
Chimney diameters	mm	80/125	80/125

**INSTALLATION****5. INSTALLATION****5.1 Warnings**

- (i)** *The combustion products of the boiler must be bleed directly to the outside or a chimney designed for these purposes, in accordance with the national and local regulations in force. The device is not suitable for receiving the condensing water from the combustion exhaust system.*
- (i)** *The air, which is used for combustion must not contain chlorine, ammonia or alkaline substances. Installing the boiler near a swimming pool, washing machine or laundry room will result in the presence of a mixture of aggressive substances in the air.*

Before installation, **it is mandatory** to thoroughly flush all system piping with non-aggressive chemicals. The process is necessary to remove all kinds of sediments and contaminants that may prevent the boiler from working properly. After flushing, the system must be treated. The standard warranty does not cover repair of possible malfunctions resulting from failure to follow the above instructions.

**Please check:**

- Whether the boiler is suitable for the type of gas, which is used (check the sticker).
- Whether the characteristics of the electricity, gas and water supply networks correspond to the data indicated in the table.

It is necessary to use only the manufacturer's chimney flue kits for flue gas extraction, due to the fact that they are the integral parts of the boiler. The pressure relief valve must be connected to the drain line to prevent flooding in the event of its activation. The condensate drain siphon must be connected to the domestic condensate drainage pipe. It must be designed in such a way that it can be checked and prevent condensate from freezing (according to the standard UNI 11071/08).

Electrical connections must comply with the technical standards given below:

- The boiler **must** always be connected to a reliable earthing system via a special terminal.
- A double-pole switch must be installed near the boiler to ensure complete shutdown of the boiler under category III over-voltage conditions. For electrical connections, see "Electrical diagram" on page. 18.
- **The electrical wires for connecting the remote control and external sensor to the boiler must be located in trays other than 230 V wire trays, as they are low-voltage.**

**5.2 Safety precautions for the installation**

- (i)** *During the installation, instructions below must be followed strictly:*
  - Mount the boiler on a solid wall;
  - Observe the dimensions of the chimney (see the section "Dimensions and lengths of the chimneys" on page 23) and the correct installation methods are given in the instructions of the chimney flue kit insert.
  - Please leave a minimum of free space around the boiler, see Figure 5.1.

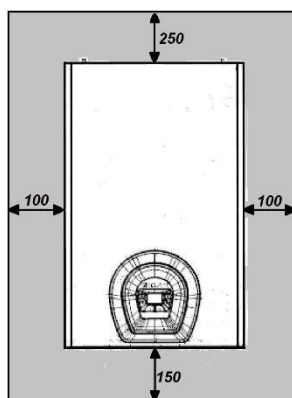
**Figure 5.1**

All of the measures are given in mm.

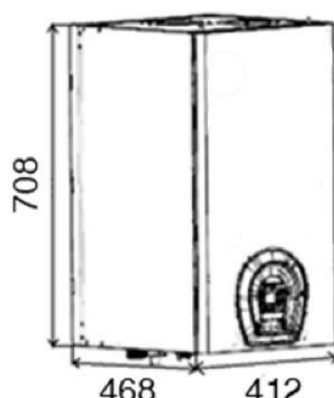
**Figure 5.2**

- It is recommended that the system is equipped with an appropriate sediment filter or use a means to prepare the water circulating in it. In particular, the latter solution will not only clean the system but will also have an anti-corrosive effect by forming a protective film on the metal surfaces and neutralizing the gases present in the water.
- Leave 5 cm of free space in front of the boiler in case it is installed in a cupboard, panel or indentation;
- If the boiler is installed in place of the previous one, the installation site should be thoroughly washed and cleaned.

- (i)** **Filling up the heating system:**

If the boiler is installed in rooms where the room temperature may fall below 0 °C, it is recommended to take the necessary precautions to avoid damaging the boiler.

  - Please do not add anti-freeze and anti-corrosion agents to the heating system water in inappropriate concentrations and/or with physical and chemical characteristics incompatible with the hydraulic components of the boiler. The manufacturer accepts no responsibility for any damage caused in that case.

**It is necessary to inform the user about the frost protection function of the boiler and the chemicals introduced into the heating system.**

### 5.3 Installation of the boiler

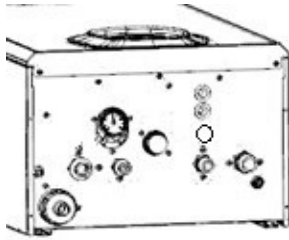

Figure 5.3

- Remove the protective plugs from the boiler outlets.
- Mount the boiler on a bracket.
- Screw the taps to the boiler.
- Assemble the spigots on the inlet, and outlet of the hot water circuit and on the gas, outlet, and return of the heating circuit.
- Connect the pipelines to the appropriate boiler taps and connections.
- Check the gas inlet for any leakage.
- Connect the pressure relief valve to the drain funnel.
- Insert the flexible condensate drain piping into the house condensate drain piping or the drain funnel of the pressure relief valve, if the drain is suitable for acid condensate.

### 5.4 Connection of buffer tank sensor and external 3-way motorized valve

Connect the buffer tank sensor to pins 1(black) and 2(black) on terminal 5.

The connection order is not essential.

Connect the external 3-way motorized valve to 4L (heating circuit - red), 5L (tank heating - yellow) and 6N (neutral - black) on terminal 11.

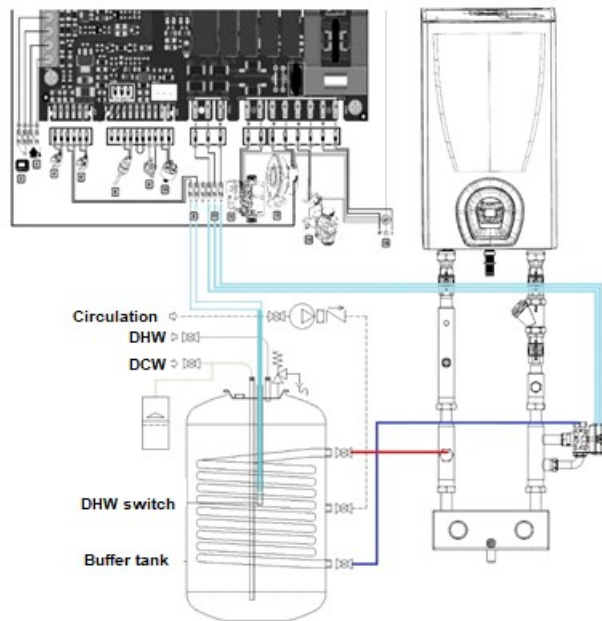

Figure 5.4

## 5.5 Dimensions and lengths of the chimneys

The flue vent/air intake can be in the following types: C13 C33 C43 C53 C63 C83 B32P

See insert inappropriate kit packaged separately. Horizontal sections of the chimneys should have a slope of about 1.5 degrees (25 mm per m).



**The outlet pipe must be located higher than the inlet pipe on the boiler side.**

Only the coaxial pipe with a diverter must be horizontal, as the diverter is already manufactured with the necessary inclination. The kits described below for connection to the boiler are available.

## 5.6 Wall-mounted chimney kit

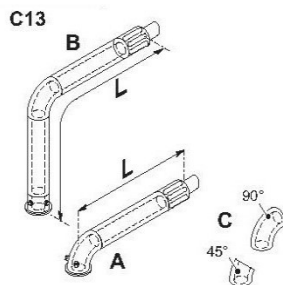

Figure 5.8

Coaxial pipe  $\varnothing$  60/100 mm with a nominal length of 915 mm. This kit allows the flue gases to be vented into the wall behind or to the side of the boiler. The minimum length of the pipe must not be less than 0.5 m and the maximum length, realized with the usage of extensions, must not exceed 2 m.

### Vertical chimney kit with 90° elbow (Figure 5.8 B)

Coaxial pipe  $\varnothing$  60/100 mm. This set allows to raise the boiler outlet axis by 635 mm. The length must not be less than 0.5 m and the maximum length including extensions must not exceed 2 m horizontally in any case, the exhaust pipe must vent the flue gases horizontally. When installing these elbows in the chimney, the maximum length of the chimney is reduced in such a way:

For 45° elbow reduction	0.5 m
For 90° elbow reduction	1 m

### Kit of split air intake and flue gas venting pipes $\varnothing$ 80 mm (Figure 5.9 - Figure 5.10) - (Figure 5.11)

This kit allows to separate the air intake and flue gas venting pipes.

The diverters can be connected to appropriate specially designed air intakes or venting and the air intake can be routed directly through the wall. Note: if the boiler is provided with a split chimney kit, a diaphragm must be inserted between the boiler and the air intake pipe. The diaphragm is supplied together with the split flue kit  $\varnothing$  80 mm (Figure 5.9).

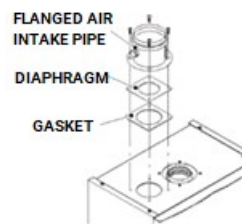

Figure 5.9

**Notification: The air intake and venting diverters must not be located on opposite walls of the building. (EN 483).**

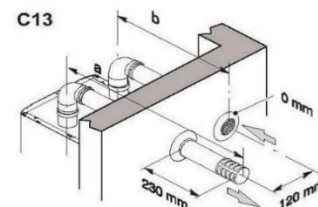

Figure 5.10

The minimum pipe length must not be less than 0.5 m and the maximum length realized with the use of extensions on sections A + B must not exceed 40 m.

90° and 45° elbows  $\varnothing$  80 mm are also available to reduce the total maximum pipe length:

For 45° elbow reduction	0.5 m
For 90° elbow reduction	1 m

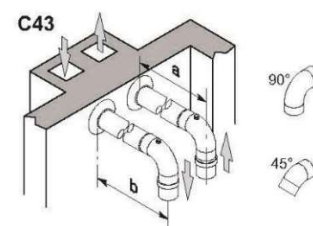

Figure 5.11

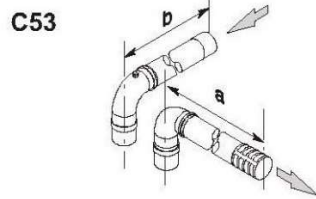

Figure 5.11

If pipelines and diverters from another manufacturer (type C63) are used, they must be compatible with the system and the flue gas pipeline must be made of materials resistant to condensation products. When dimensioning the pipes, it is necessary to take into account the residual head of the fan (see the following table).

Useful static pressure at nominal heat output	25 kw	90	Pa
	35 kw	90	Pa
Excessively high flue gas temperature	25 kw	93	°C
	35 kw	98	°C
Maximum CO2 circulation in the absorption tube	25 kw	0.95	%
	35 kw	0.95	%

### Type C83 (Figure 5.12)

A boiler on which this type of venting is installed must draw combustion air from the outside and vent the flue gas through a separate or common chimney designed for such purposes.

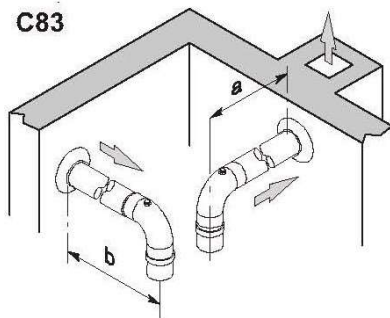

Figure 5.12

### Chimney kit through the roof (Figure 5.13)

Ø 80/125 mm coaxial pipe nominal length 0.96 m. This kit allows the flue gas to be vented directly from the roof.

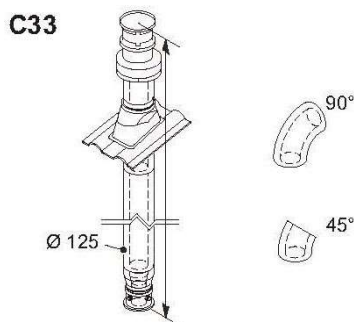

Figure 5.13

Extension cables are available to attain the maximum height. The maximum height with extension cables is 10 meters. Coaxial elbows 90° and 45° Ø 80/125 mm can also be used to reduce the total maximum pipe length:

For 45° elbow reduction	0.5 m
For 90° elbow reduction	1 m

### Type B23P (Figure 5.14)

This type of chimney takes the air, which is required for the combustion, directly from the room where the boiler is installed and vents the combustion materials to the outside; it can be wall-mounted or tubular.

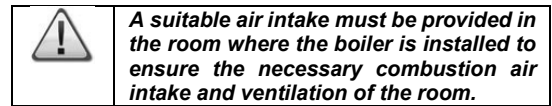

For the efficient operation, the minimum air exchange should be 2 m<sup>3</sup>/h per kW of heat output.

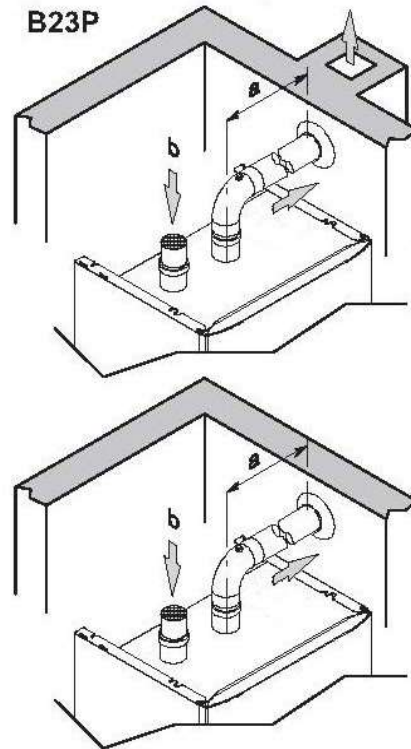
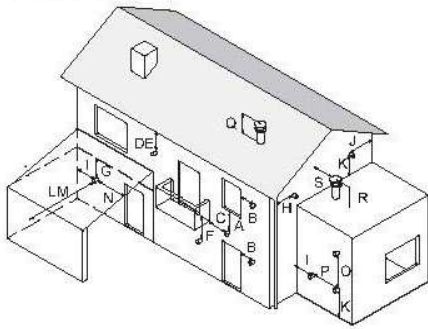

Figure 5.14

### 5.7 Placement of the exhaust diverters

Exhaust diverters should:

- be located on the exterior walls of the building or the roof;
- be installed in accordance with the minimum distances Figure 5.15 and applicable national and local regulations.

**Figure 5.15**
**Placement of the connection pipes**

- A** Under a window or other opening 600 mm
- B** Close to a window or door 400 mm
- B** Close to an aeration or ventilation opening 600 mm
- C** Next to a balcony 1,000 mm
- D** When under gutters or drainage pipes 300 mm
- E** Under cornice overhangs 300 mm
- F** Under a balcony 300 mm

- G** Under a garage roof **DO NOT**
- H** From vertical drainage pipes 300 mm
- I** From internal corners 300 mm
- J** From external corners 300 mm
- K** From the ground or other walkable surfaces 2200 mm
- L** From an exiting front surface without openings 2000 mm
- M** From an exiting front opening 3000 mm
- N** From an opening in garage **DO NOT**
- O** Between two vertical diverters on a same wall 1500 mm
- P** Between two horizontal diverters on a same wall 1,000 mm
- Q** Above a roof slope with a pitch less than or equal to 30° \* 350 mm
- Q** Above roof pitches greater than 30° \* 600 mm
- R** Above flat roof \* 300 mm
- S** From walls \* 600 mm
- S** From two corner walls \* 1,000 mm
- \* Diverter pipe on roof

**GAS ADJUSTMENTS**
**6. GAS ADJUSTMENTS**
**6.1 Preliminary operations before the first commissioning**

The first commissioning, includes checking the correct installation, configuration and operation of the appliance.

Procedure:

- Check whether the boiler can work with the type of gas used.
- Check whether the capacity of the gas line and the related pressure in the system correspond to the instructions indicated on the information label.
- Check whether the safety devices are functioning in the event of an insufficient gas supply.
- Make sure that the supply voltage corresponds to the value indicated on the information label (230 V, 50 Hz) and that the electrical connections have been properly made.
- Check whether the grounding is working properly.
- Make sure that the air intake for combustion, flue gas ventilation, and condensate drainage have been properly installed in accordance with applicable local and state laws and standards.
- Make sure that the shut-off valves of the heating system are open.
- Make sure there are no flammable materials or liquids close at hand of the appliance.
- Switch on the gas valve of the appliance and make sure that there are no gas leaks. The gas connection of the burner must be checked during the operation of the boiler.
- If the gas supply has been recently installed, the air contained in the pipes may block the equipment during the commissioning. To bleed the air from the pipes, repeat the start-up procedure.

**6.2 Access to the internal parts of the boiler**

1. Unscrew the screws **1**, which secure the top cover **2**;
2. Push panel **2** up and out and remove it from tabs **3**;
3. Unscrew the screws **4**, lift the control panel **5** and tilt it downwards;
4. Unscrew the two screws **6** that secure the bottom of the cover, then pull it towards you. Then lift it upwards by unhooking it from the pins **3**;
5. After performing operations that require access to internal components, cover the combi boiler in reverse order, paying particular attention to fixing the top cover **2** to tabs **3**.

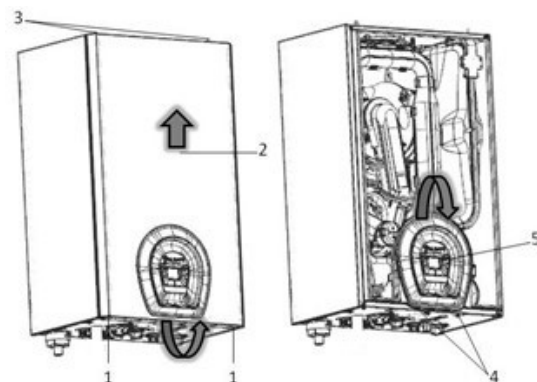
**Figure 6.1**

### 6.3 Filling the condensate drainage siphon

Before commissioning the appliance, fill the condensate trap to prevent flue gases from escaping through the trap.

The procedure for filling the trap is as follows (Figure 6.2).

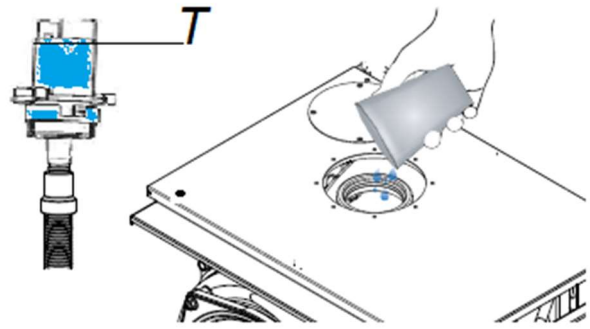

Figure 6.2



### 6.4 Commissioning the boiler

#### **WARNING!**

Make sure that the system is filled correctly.

The procedure for putting the boiler into operation is as follows:

- Before commissioning the boiler, make sure that the circulation pump is not blocked due to a break in operation: loosen the plug, and turn the rotor manually with a screwdriver or other suitable tool through the hole in the centre. Tighten the plug, and make sure that the plug is not leaking.
- Before commissioning the boiler, fill the condensate trap to prevent flue gases from escaping through the trap.
- Check whether the produced heat can be utilized by the radiators (and/or radiator panels/floor systems) or through the DHW circuit.
- Switch the appliance on.
- Turn on the gas valve.

- Use the  button to adjust the operation mode. If the symbol on the display flashes, operation in the selected mode is activated.
- If no flame is detected, an additional purge will be performed and the motherboard will send a restart command.
- If air has accumulated in the gas pipe, repeat the start-up procedure several times. Press the  button (E 01 error) to unlock the appliance before starting.



### 6.5 Control and adjustment of CO<sub>2</sub> concentration

#### **WARNING!**

The CO<sub>2</sub> concentration test is performed with the front cover assembled. Take out the front cover to adjust the gas valve.

To check and adjust the CO<sub>2</sub> concentration at minimum and maximum output, follow the steps below:



#### For minimum output in the heating mode

- Press and hold the  and  buttons to activate the chimney sweep function, and the display will show "CSF" (the maximum duration of the function is 240 seconds), then press  to calibrate the minimum power in heating mode, and the display will show "LO".

- Insert the flue gas analyzer probe (Figure 6.3) into the appropriate flue gas analysis fitting "PF", afterwards check whether the CO<sub>2</sub> value corresponds to the one given in the "Technical menu" section, otherwise unscrew the protective screw "A" and adjust the screw "2" of the offset regulator (Figure 6.4) using the hexagonal wrench 4. In order to increase the value of CO<sub>2</sub>, it is necessary to rotate the screw clockwise, and to decrease it - counterclockwise. After completing the adjustment, tighten the safety screw "A" on the offset adjuster.

#### For maximum output in the heating mode

- Press the  button to calibrate the maximum output in the heating mode, and the display will show "HI".
- Check whether the CO<sub>2</sub> value corresponds to that given in the "Technical menu" section, otherwise adjust the screw "1" of the gas supply regulator (Figure 6.4). To increase the CO<sub>2</sub> value rotate the screw counterclockwise and decrease it - clockwise.

- Each time you change the setting of the gas supply regulator screw "1", you must wait for the boiler to stabilize for the set value (approx. 60 seconds).
- Then press the  button and check whether the CO2 value at the minimum has changed, if so, repeat the calibration process described in the previous paragraph.
- Press to  deactivate the chimney sweep function.

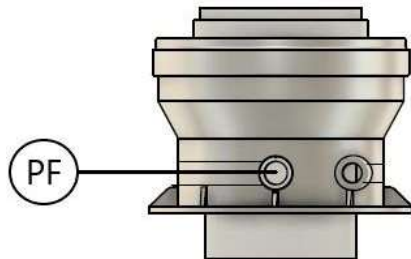

Figure 6.3

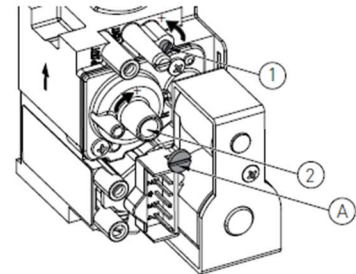



Figure 6.4







## Parameter adjustments (Technical menu)

### 7. Parameter adjustments (Technical menu)

#### 7.1 Accessing the parameters



Pressing the  and  buttons simultaneously for 4 seconds allows access to the parameter menu. In the parameter menu the symbols "P" and "00" will be displayed, every 3 seconds the parameter number and its value are alternately shown on the display

#### 7.2 Making adjustments





Press the  or  button to change the parameter number. To enter a parameter, press the button , the value of the parameter is changed by pressing the  and  buttons. Press the  button to save the selected value. To exit the technical menu, press the  button. If any action is not performed for 240 seconds, the parameter menu is automatically closed without saving the changes.

#### 7.3 Adjusting the parameters (technical menu)

Parameter number	Parameter designation	Factory setting	Adjustment range
P00	Boiler type	1	1 – Double circuit 2 – Only heating 3 – Single circuit
P01	Burner configuration	1	1 - 14
P02	Heating type	0	0 – Radiator 1 – Underfloor heating
P03	Fan speed during ignition (Hz)	80 Hz	40 – 255 Hz
P04	Minimum fan speed for DHW circuit (Hz)	70 Hz	33 – 100 Hz
P05	Maximum fan speed for DHW circuit (Hz)	235 Hz	100 – 300 Hz
P06	Minimum fan speed for DHW circuit (Hz)	70 Hz	33 – 100 Hz
P07	Maximum fan speed for DHW circuit (Hz)	235 Hz	100 – 300 Hz
P08	Time to reach maximum output in heating mode	3 minutes	0 – 10 minutes
P09	Burner re-operate timing in heating mode	1 minute	0 – 10 minutes
P10	Pump "run out" time after heating operation	30 seconds	0 – 240 seconds
P11	-	Can not be changed	-
P12	Fan speed in purge mode	100 Hz	40 – 255 Hz

<b>P13</b>	Display value	0 °C	0 – °C 1 – Hz
<b>P14</b>	Pump "run out" time after DHW operation	30 seconds	0 – 240 seconds
<b>P15</b>	-	Can not be changed	-
<b>P16</b>	-	Can not be changed	-
<b>P17</b>	-	Can not be changed	-
<b>P18</b>	-	Can not be changed	-
<b>P19</b>	-	Can not be changed	-
<b>P20</b>	Outdoor air sensor correction	20	5 - 35
<b>P21</b>	DHW flow type	16	0- Flow switch 1-9 Unavailable 10-40 Flow sensor. DHW switching frequency in Hz
<b>P22</b>	-	Can not be changed	-
<b>P23</b>	-	Can not be changed	-
<b>P24</b>	-	Can not be changed	-
<b>P25</b>	Water pressure control type in the heating circuit	0	0 – Water pressure switch 1 – Water pressure switch with 0.5-2.5 V output 2 – Water pressure sensor with 0.5-3.5 V output
<b>P26</b>	Heating circuit outlet line temperature limit for DHW operation	0	0 – Off 1 – On
<b>P27</b>	-	Can not be changed	-
<b>P28</b>	Domestic hot water hysteresis	3°C	1-10°C
<b>P29</b>	CH temperature delta in buffer tank heating mode	10°C	5-20°C
<b>P30</b>	Anti Legionella	7 days	0 – Off 1-15 Days
<b>P31</b>	Flue gas sensor configuration	1	0 – Off 1 - Active
<b>P32</b>	Burner re-operate timing in DHW mode	3 minutes	0 – 10 minutes
<b>P33</b>	Maximum output in buffer tank heating mode	100%	0% - 100%
<b>P34</b>	Display backlight configuration	0	0 – Active for 60 seconds 1 – Active on  and  demand, active in standby mode for 60 seconds 2 – Active
<b>P35</b>	Temperature interval for switching on the burner	0 °C	1-10°C

#### 7.4 Information menu

Pressing the  and  buttons simultaneously for 6 seconds allows access to the information menu. In the information menu the icons "∩" and "01" will be displayed indicating the activation of the information menu, every 3 seconds the parameter number and its value are alternately shown on the display. Press the  or  button to change the parameter number. To exit the technical menu, press the . If no action is performed for 240 seconds, the information menu closes automatically.

Parameter number	Description
- 0 -	Actual heating circuit temperature (°C)
- 1 -	Actual DHW temperature (°C)
- 2 -	Actual burner output (%)
- 3 -	Actual heating circuit return line temperature (°C)

- 4 -	Actual outdoor air sensor temperature (°C)
- 5 -	Actual fan speed (rpm/10)
- 6 -	-
- 7 -	Actual flue gas temperature (°C)
- 8 -	Target fan speed (rpm/10)
- 9 -	-
- a -	Estimated heating setpoint temperature (°C)
- b -	The last error code
- c -	The second last error code
- d -	The third last error code
- e -	The fourth last error code
- f -	The fifth last error code

## MAINTENANCE

### 8. MAINTENANCE

#### 8.1 WARNINGS

**(i)** *The actions described in this section must only be performed by a qualified technician. It is recommended to contact an authorized service centre.*

*To ensure the reliable and continuous operation of the boiler, it is necessary to have it maintained and cleaned once a year by an authorized service centre. If this work is not carried out, the warranty does not cover the replacement of damaged parts and repair of possible malfunctions. Before performing any cleaning, maintenance, opening or dismantling of the panels, it is necessary to **disconnect the boiler from the mains** by a double-pole switch provided at the installation and **switch off the gas valve**.*

#### 8.2 General safety precautions during the maintenance



**DANGER!** *Always disconnect the appliance from the electric network, water and gas mains before any replacement or cleaning of the components.*



*Use only original spare parts during maintenance to ensure the efficient operation of the equipment.*



*To ensure the efficient and safe operation of the boiler, the boiler must be maintained annually. Failure to do so will result in the forfeiture of the right to warranty repair at the Federica Bugatti Service Center. For this reason, only a qualified technician who has been certified by Federica Bugatti is allowed to work on the boiler.*

#### **Annual maintenance consists of the following operations:**

- Make sure that the pH value of the water in the system is between 6.5 and 8.5.
- Check the gas connections for leaks, and replace gaskets if necessary.
- Check the hydraulic connections for leaks, and replace gaskets if necessary.
- If necessary, make sure that the combustion parameters are set correctly, in case of deviations, re-adjust the combustion parameters. The procedure is described in the section "**Checking and adjusting the CO2 concentration**".
- Check the condition of the primary heat exchanger, clean if necessary.
- Check the ignition and safety systems for proper operation. If necessary, dismantle the ignition and flame ionization electrode and clean it from deposits. The distance between the electrode and the burner must remain unchanged.
- Check the heating circuit safety components: pressure relief valve, safety thermostat, water pressure sensor and flue gas sensor.
- Check the pressure of the expansion tank (when empty).
- Check the permanently open vents, their size and efficiency about the requirements of the installed equipment and local and national regulations.
- Regularly check the integrity of the flue gas system to ensure the safe and correct operation of the appliance.
- Make sure that the electrical connections are made according to the instructions given in the manual.
- Check the electrical connections in the control panel.

- Check the DHW flow rate and temperature.
  - Check the function of the condensate drainage system, including components located outside of the boiler, e.g. condensate neutralization units for a condensate with a high acid content.
- Make sure there are no obstructions to liquid flow and flue gases are not leaking into the system.

**NOTE:** During the annual maintenance, the thermal management and energy efficiency also must be checked. The frequency and methodology of the inspection must comply with the instructions of applicable legislation. **Do not clean the boiler or components with flammable substances (e.g. gasoline, alcohol, etc.). Do not clean the panels, painted parts and plastic parts with products, which are contain paint thinner solutions. The exterior parts of the boiler must be wiped with a damp cloth.**

**8.3 Remarks on Scheduled Maintenance**

Maintenance date	Name of the organization	Full name of the technician	Contact number	Technician's signature

**WARRANTY CONDITIONS**

**9. WARRANTY CONDITIONS**

Federica Bugatti guarantees the real quality. For installation, commissioning, subsequent maintenance and repair, it is recommended to contact an authorized Federica Bugatti Service Center. According to the contract with Federica Bugatti, the company will eliminate free of charge during the warranty period all the defects which occurred due to the fault of the manufacturer. The warranty period is 24 months from the date of putting the appliance into use, but not more than 27 months from the date of purchase by the owner of the appliance.

**1. Regulations in the event of a handover of the equipment.** 1.1. When purchasing the appliance, the owner inspects and checks the quality and completeness of the equipment. Claims on the appearance, presence of any external mechanical damage and incompleteness of the equipment after the sale. 1.2. Demand that the warranty card be filled out! **2. Installation and commissioning.** 2.1. Installation and commissioning of the equipment is performed in full compliance with the manufacturer's instructions. 2.2. Installation and commissioning of the equipment must be carried out by an authorized Federica Bugatti service center, or by a specialist who has all permits for maintenance and repair of the equipment, who has been certified and received a certificate from Federica Bugatti Ltd. 2.3 The organization that performed installation and commissioning of the equipment fills in the protocol (act) on the performed work and puts corresponding marks in the warranty card. The warranty period for the equipment in the presence of a completed product identification sheet, sales and commissioning data, as well as a completed protocol (act) on the commissioning of the equipment, is 24 months from the date of commissioning, but not more than 27 months from the date of purchase by the owner of the equipment. **3. Maintenance of the appliance.** 3.1. After commissioning the device, the owner of the boiler is obliged to conclude a contract for annual maintenance of the appliance. For maintenance, it is recommended to contact Federica Bugatti authorized service centres, whose technicians are certified to perform the above-mentioned operations. The maintenance is performed in accordance with the manufacturer's instructions at least once a year, and in some cases, on the recommendation of the service organization, even more often, in accordance with the conditions of the used heating medium requirements and other features of the appliance operation, which differ from those declared by the manufacturer. 3.2 Please note that the installation, commissioning, maintenance and service works are performed on a reimbursable basis.

**4. Warranty registration.** 4.1. If a malfunction is detected, cut the power, and switch the water and gas supplies off. Do not attempt to dismantle or repair the device by yourself. For prompt and quality maintenance or warranty repairs, please contact an authorized Federica Bugatti service centre in your area. In case of a situation detected by the authorized service centre regarding the appliance malfunction, which occurred due to the manufacturer's fault, the equipment is subject to warranty repair by replacing the defective part with the correct one. 4.3. Warranty claims of the company Federica Bugatti are accepted by authorized service organizations only if the following requirements are fulfilled: - commissioning is performed by an authorized Federica Bugatti service centre or by a certified Federica Bugatti technician; - all the fields of the warranty card are correctly filled in date of sale and seller's stamp, the model with the factory number of the product, date of commissioning, installation and commissioning mark (to be filled in by the service technician at the time of installation and commissioning); the commissioning protocol (act) of the appliance is filled in; the power supply system, fuel supply system, heat carrier, as well as exhaust system of the combustion products must have technical characteristics and be connected in full compliance with the requirements of the documents for safe operation, service and maintenance of the equipment; - completion annual technical maintenance. 4.4 Warranty obligations shall be invalidated in the following cases: - the product was not used for its intended purpose; - the conditions of herein the warranty are not fulfilled; - mechanical or thermal damage is detected on the appliance body, as well as traces of liquid, dirt and dust, which could be the cause of a part failure or an inoperability of the appliance; - installation, commissioning, maintenance, repair of the appliance were performed by unauthorized persons; - making design changes on the appliance. 4.5. To ensure more reliable operation of the appliance in accordance with the local operating conditions (parameters of the electricity, gas, and water supplies) and prevent malfunctions, it is recommended that installing additional components: voltage stabilizer, surge protector, dielectric on the gas pipe, filtration system, etc. 4.6. Federica Bugatti does not assume any other obligations or responsibilities than those stated herein the warranty obligations. The current addresses of the service centres can be found on the website:

[www.federicabugatti.com](http://www.federicabugatti.com)

## 10. Warranty card

<b>Appliance model:</b>		<b>Serial number of the boiler</b>	
<b>Data of the sales organization</b>			
Name:		<b>Stamp location</b>	
Address:			
Phone number:			
Full name of the seller:			
Seller's signature:		Date of sale:	
<b>Customer data</b>			
Full name of the customer:			
Address:			
Phone number:			
I confirm that I have received the appliance in its entirety and agree to the warranty terms and conditions, I have no complaints about the appearance of the appliance.			
Customer's signature: _____			
<b>To be filled in by the organization that performed commissioning operations</b>			
<b>Organization data</b>			
Name:		<b>Stamp location</b>	
Address:			
Full name of the technician :			
Certificate number:			
<b>Appliance start-up date:</b>		<b>Technician's signature:</b>	

# series **VARME**

<b>Remarks during the start-up:</b> _____			
_____			
_____			
<i>Additional appliances:</i>			
<i>Dynamic gas pressure</i>	<i>mBar</i>	<i>Gas pressure at the burner min</i>	<i>mBar</i>
<i>Mains voltage:</i>	<i>V</i>	<i>Gas pressure at the burner max</i>	<i>mBar</i>

***I hereby confirm that the appliance has been commissioned, is in good working order, and has been instructed in the rules of operation and safety. The operating instructions for the appliance have been received, the contents are clear and understandable, I agree and undertake to comply with the operating requirements. I am familiar with and agree with the manufacturer's warranty obligations.***

***Customer's signature:*** \_\_\_\_\_



FEDERICA BUGATTI LLC.  
MANUFACTURER: VARMECOM INC., MADE IN TURKEY

[FEDERICABUGATTI.COM](http://FEDERICABUGATTI.COM)